

**NEWMARKET PRE-CAST CONCRETE PRODUCTS LTD.**  
**TELEPHONE: 905 852 6111 : TOLL FREE 1 800 263 1297**

**NEWMARKET PRE-CAST "SEA WALL"  
 CONCRETE RETAINING WALL BLOCK**

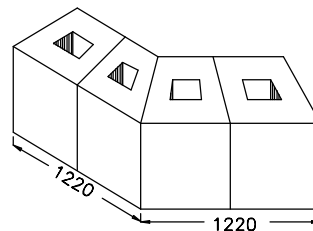
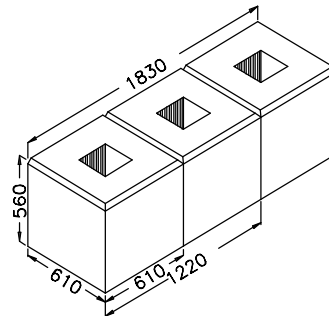
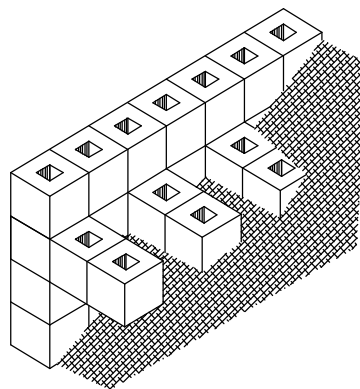
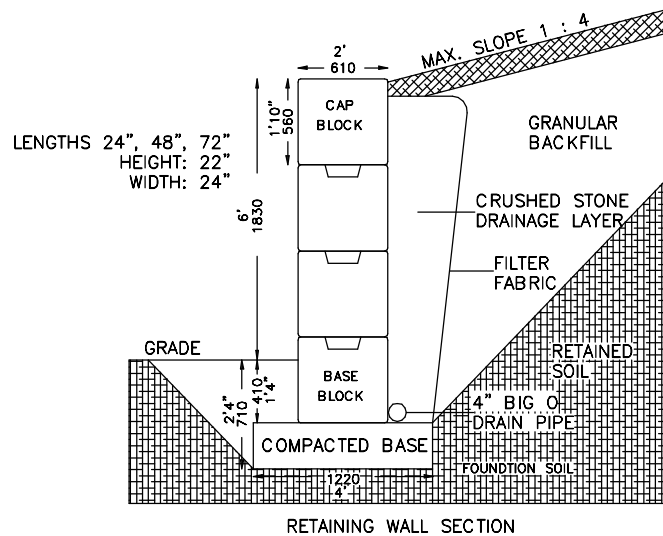

The strength and flexibility of Sea Wall can be seen in this illustration. With the optional block off, 1, 2 & 3 section blocks can be produced to take full advantage of Sea Wall's interlocking feature.

**INSTALLATION**

1. Strip topsoil and excavate down to undisturbed native soil with a bearing capacity of not less than 3000 psf (150kPa) a minimum 2'4" (710mm) below final grade at bottom of wall.

2. If overexcavation is required to remove poor material, replace with compacted granular B. Place and compact all granular backfill in 6" (150mm) layers to 95% Standard Proctor maximum dry density.

3. Compacted Base: Clear stone or granular A, installed and compacted in 6" (150mm) layers to 98% Standard Proctor maximum dry density.

4. Install first row Sea Wall Base blocks. Blocks shall be installed vertically or with a batter of 5°. The first row of blocks shall be embedded a minimum of 16" (410mm).

5. Successive rows of Sea Wall blocks shall be placed with staggered joints. Use 24" or 48" Sea Wall blocks at ends.

6. Maximum height of stacked wall shall not exceed 6' (1.82m) above grade at toe. No more than three courses of blocks shall be layered above the base block row.

7. Install drainage tile, filter fabric and crushed stone to provide drainage behind the wall as indicated. Drainage tile to extend around, through or under the wall.

8. Backfill behind wall with approved granular free draining material. Compact material in 6" (150mm) layers to 95% Standard Proctor maximum dry density.

**SPECIAL NOTES:**

1. Protect ground from freezing during construction.
2. A GUARD RAIL IS REQUIRED, to ONTARIO BUILDING CODE (OBC) SECT. 9.8.8 where the top of wall is unprotected.

**MATERIAL SPECIFICATIONS**

1. Granular Backfill: Granular B.
2. Compacted Base: Clear stone, granular A or HL-6 crushed stone.
3. "Sea Wall" blocks by Newmarket Precast.
4. Crushed Stone: 3/4" Clear Stone
5. Filter Fabric: Technitex TX-170 or equivalent
5. Concrete: 35MPa, 5 - 7% air.

45° Angle blocks available in different lengths to suit any job application.

Exposed aggregate SeaWall available for more of that natural look. Call or visit our office for colours and pricing.